

Radio Site Solution

Djerba Airport

MED_2001



RAN Department



Actual installed Solution

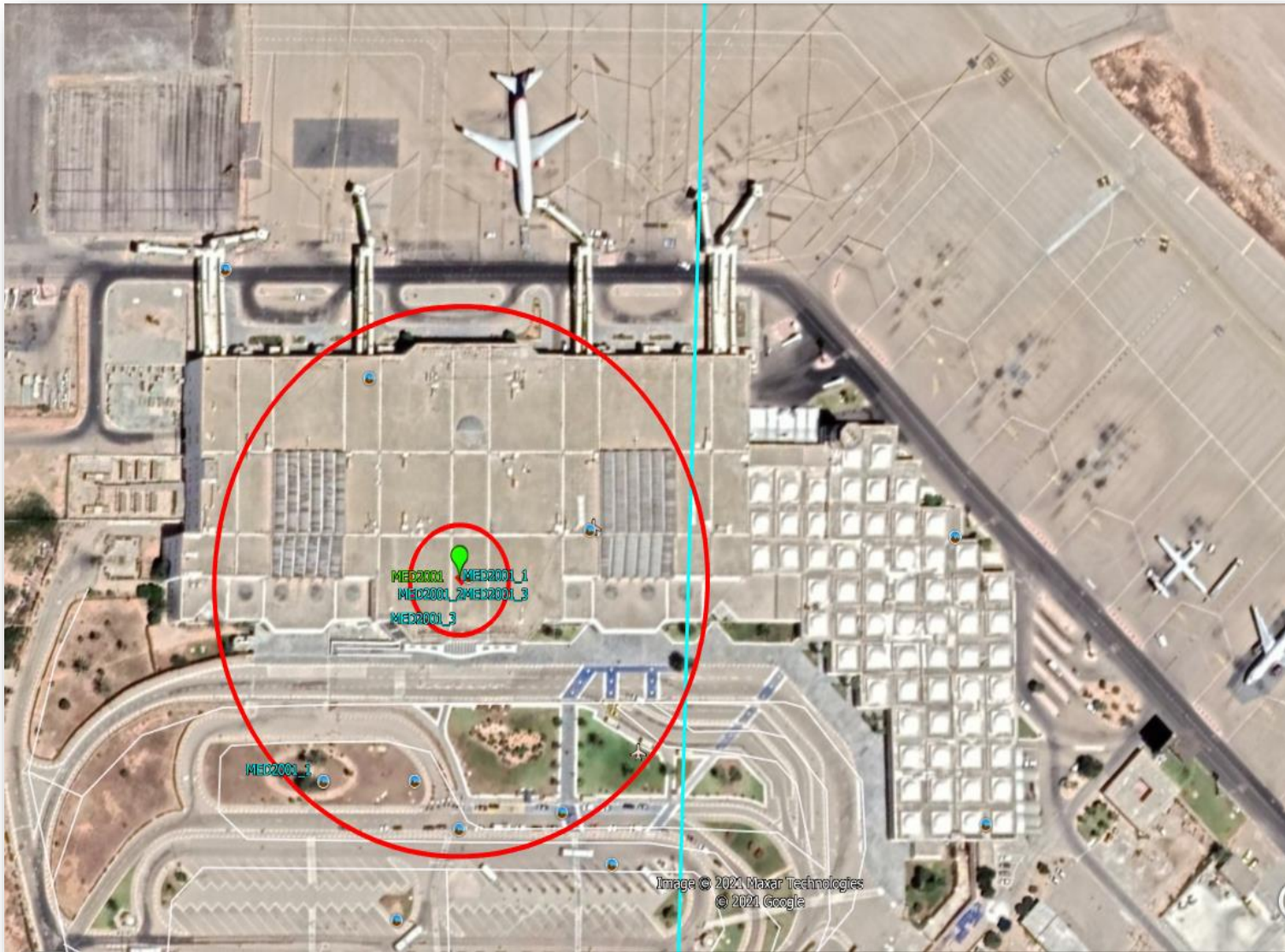

Actual Solution _ MED2001 S1

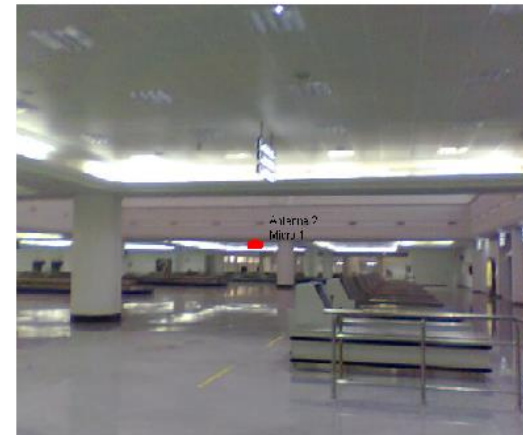
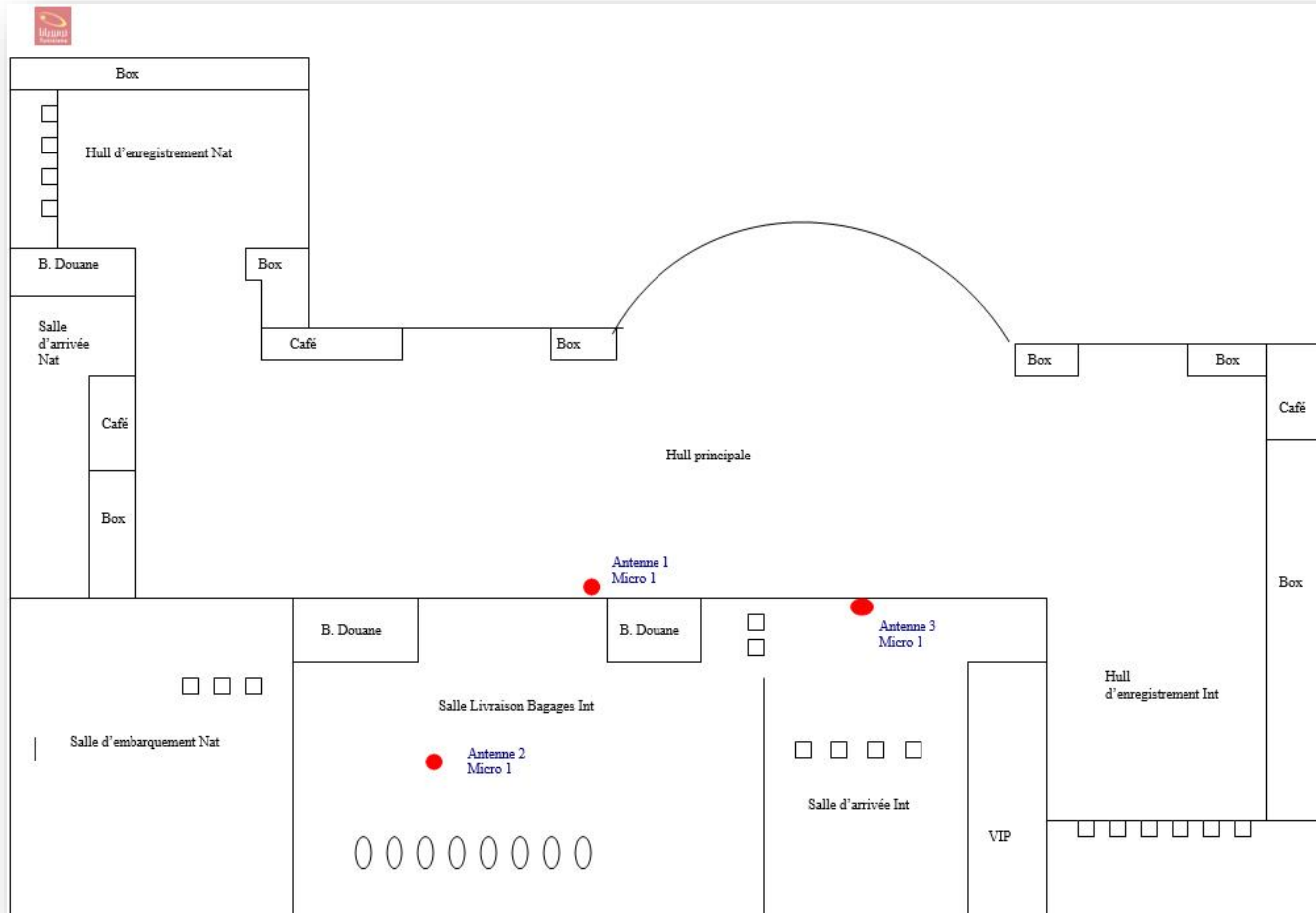

Actual Solution _ MED2001 S1



Upgrade Micro solution MED_2001

the upgrade of the Actual Radio solution is mainly programmed to :

- Solve weak coverage in many recommended space such as :
 - VIP & Presidential Room
 - Honor Corridor dedicated to Francophonie event
 - Plane landing runway
 - Ooredoo Shop
- Increase Ooredoo network coverage in Djerba Airport
- Increase Ooredoo Capacity & QoS

the Target Radio solution will be composed by 4 serving Cells

MED 2001

**Micro Site
Target Solution**

Airport_RDC Plan

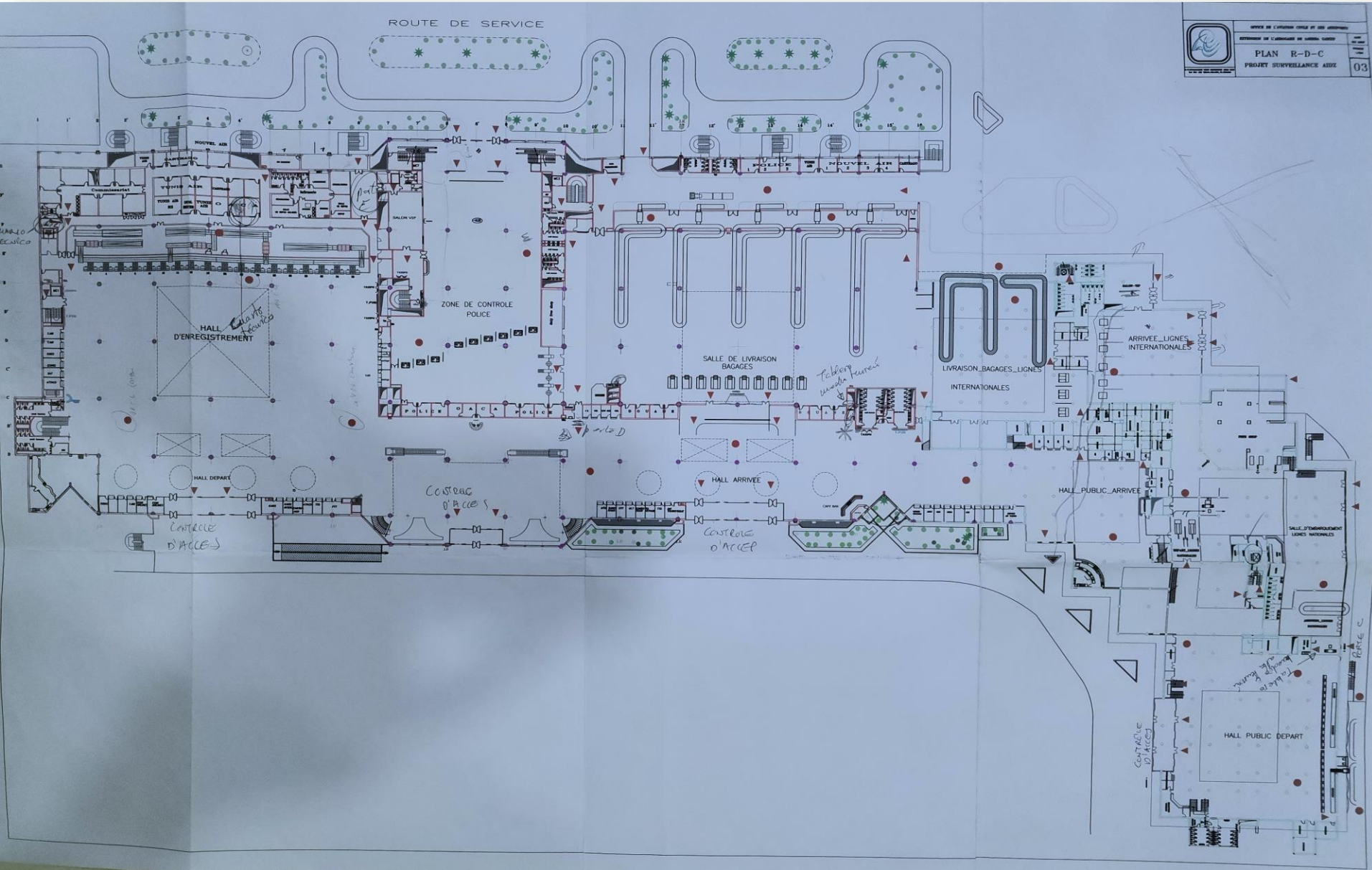

Airport_RDC Plan

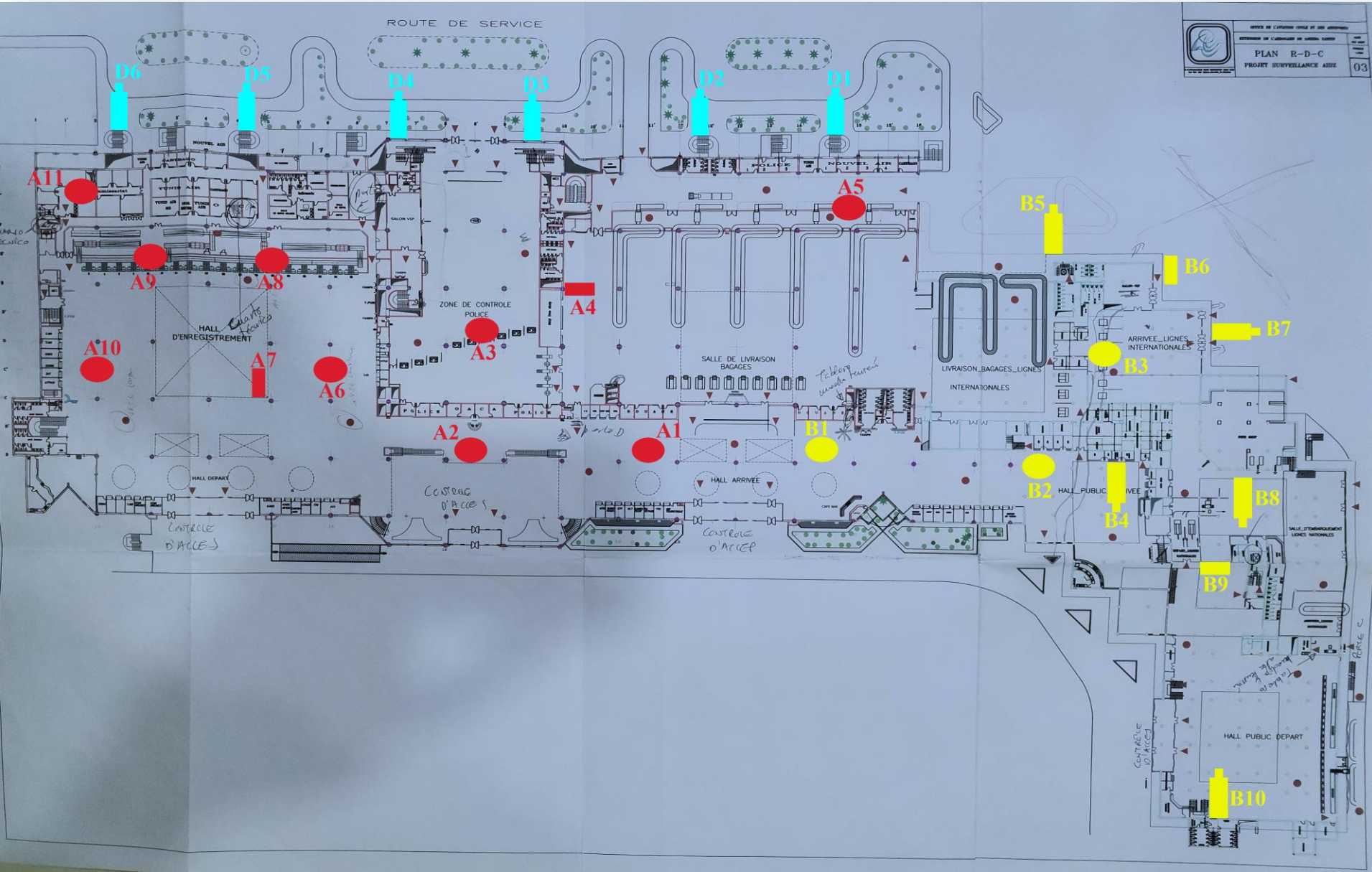

Airport_1st Floor Plan

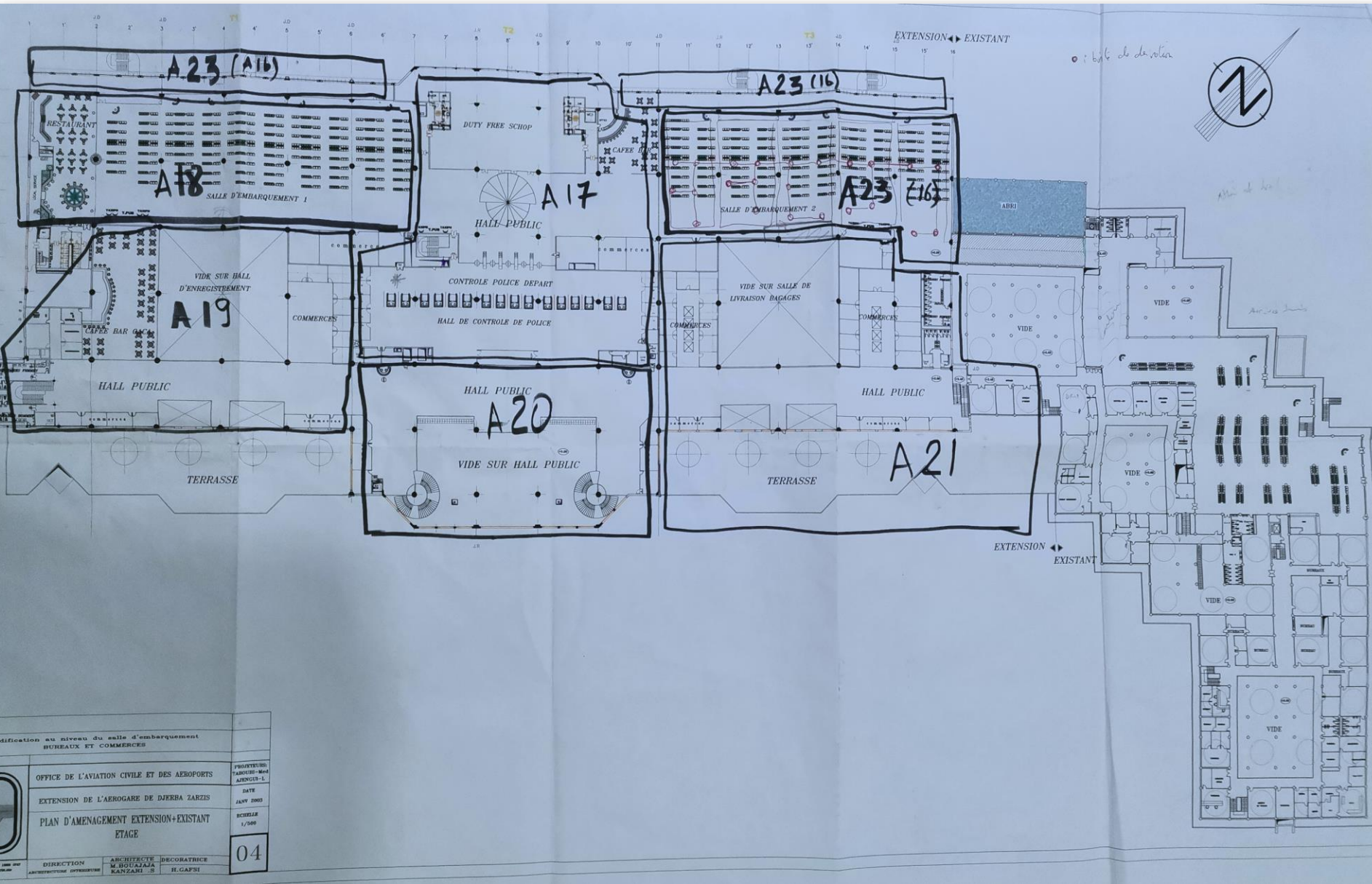

Airport_1st Floor Plan

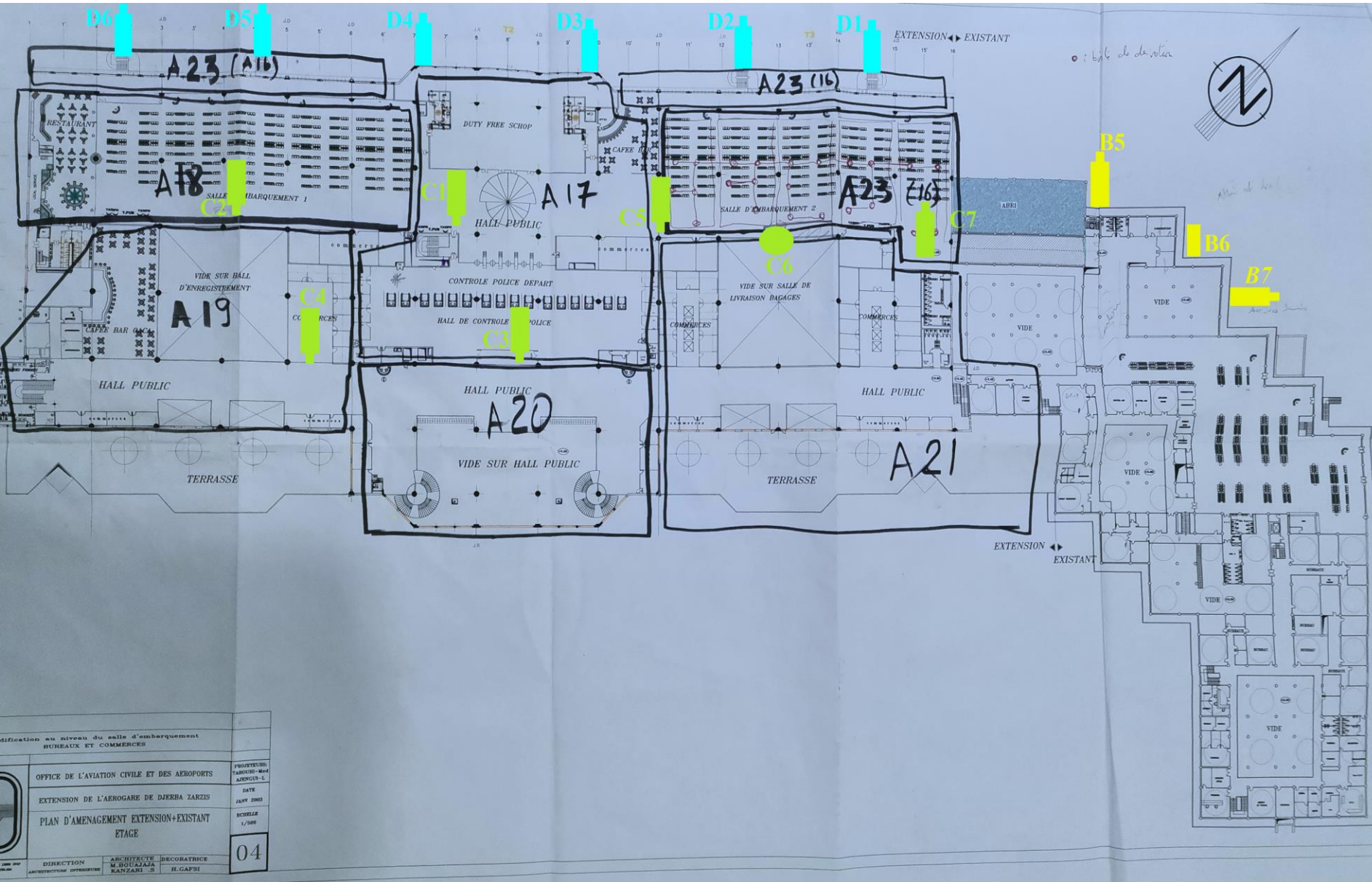

modification au niveau du salle d'embarquement BUREAUX ET COMMERCES		
OFFICE DE L'AVIATION CIVILE ET DES AEROPORTS	INGENIEUR FABOUHI-Med	AGENCIERS-L
EXTENSION DE L'AEROGARE DE DJERBA ZARZIS	DATE	JANV 2000
PLAN D'AMENAGEMENT EXTENSION+EXISTANT ETAGE	ECHELLE	1/500
DIRECTION	ARCHITECTE M. BOUJAJAJA	DECORATRICE H. CAFSI
		04

Solution Synoptic Diagram _ Sector 1

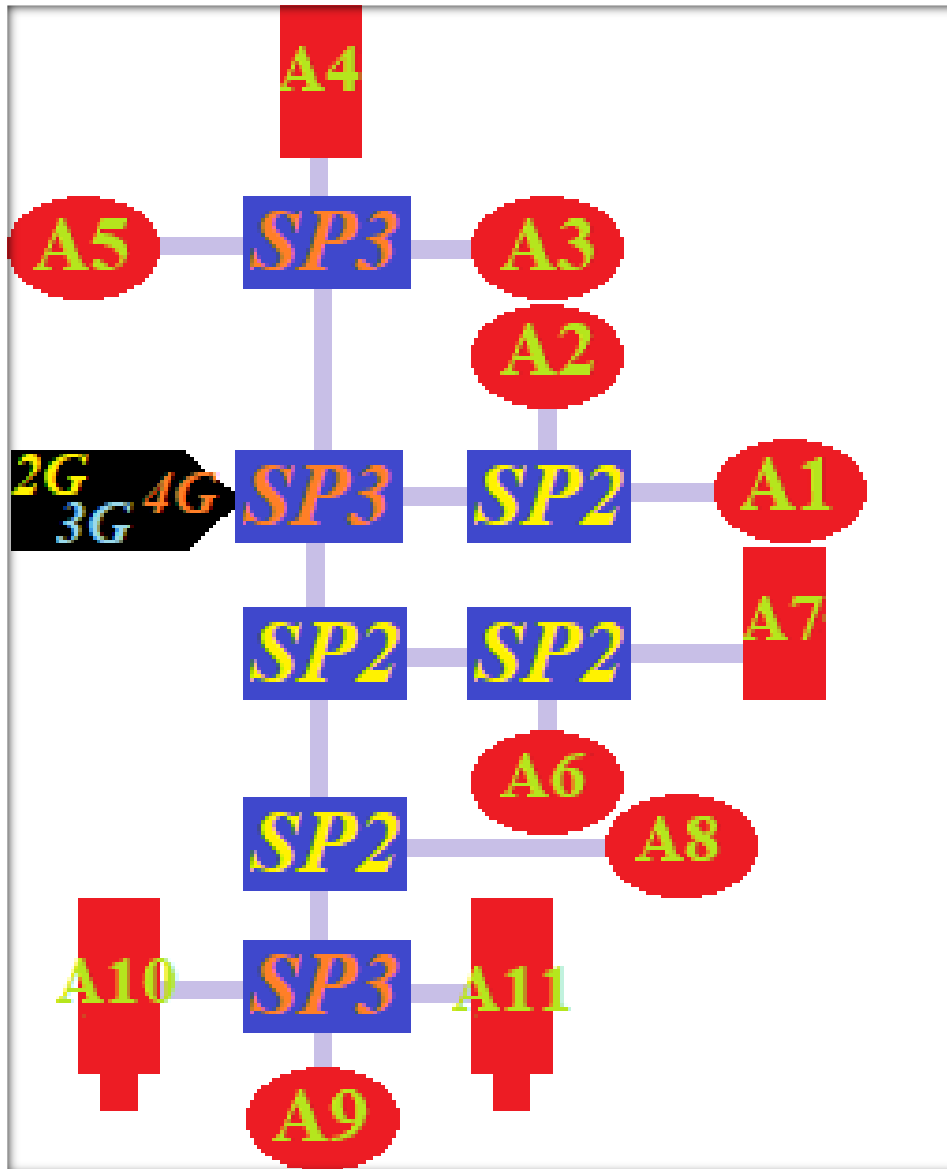

Solution Synoptic Diagram _ Sector 2

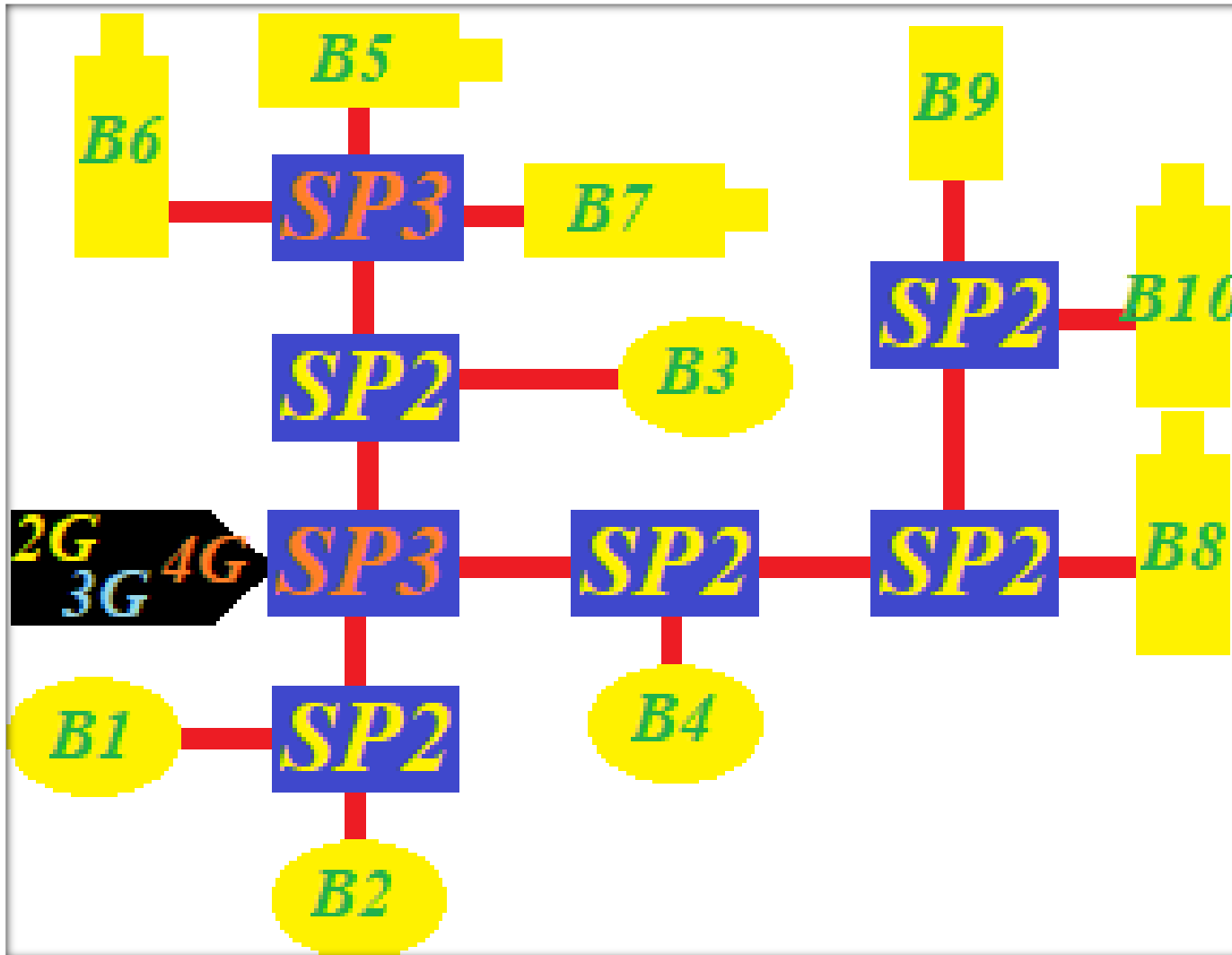

Solution Synoptic Diagram _ Sector 3

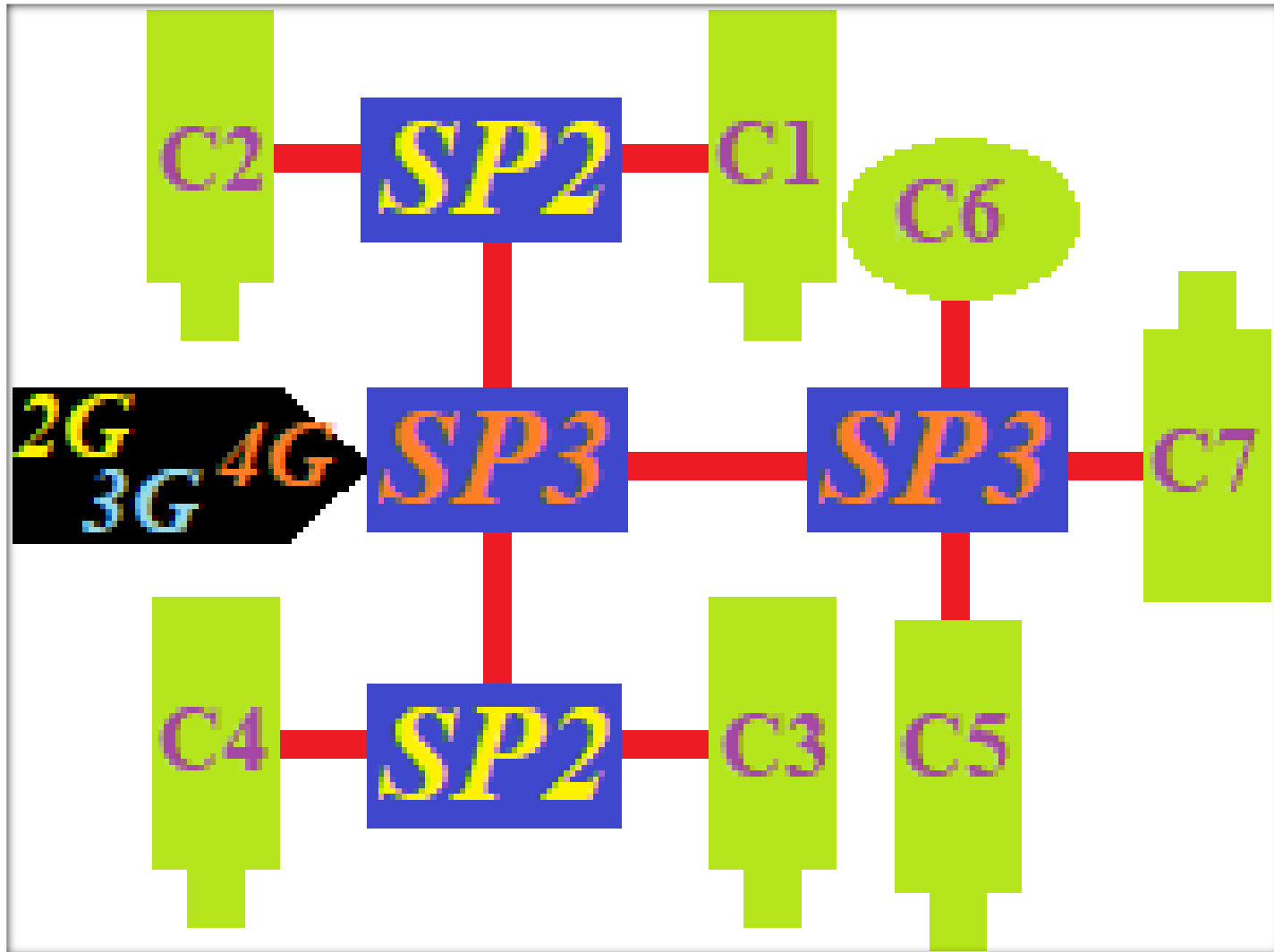

Solution Synoptic Diagram _ Sector 4

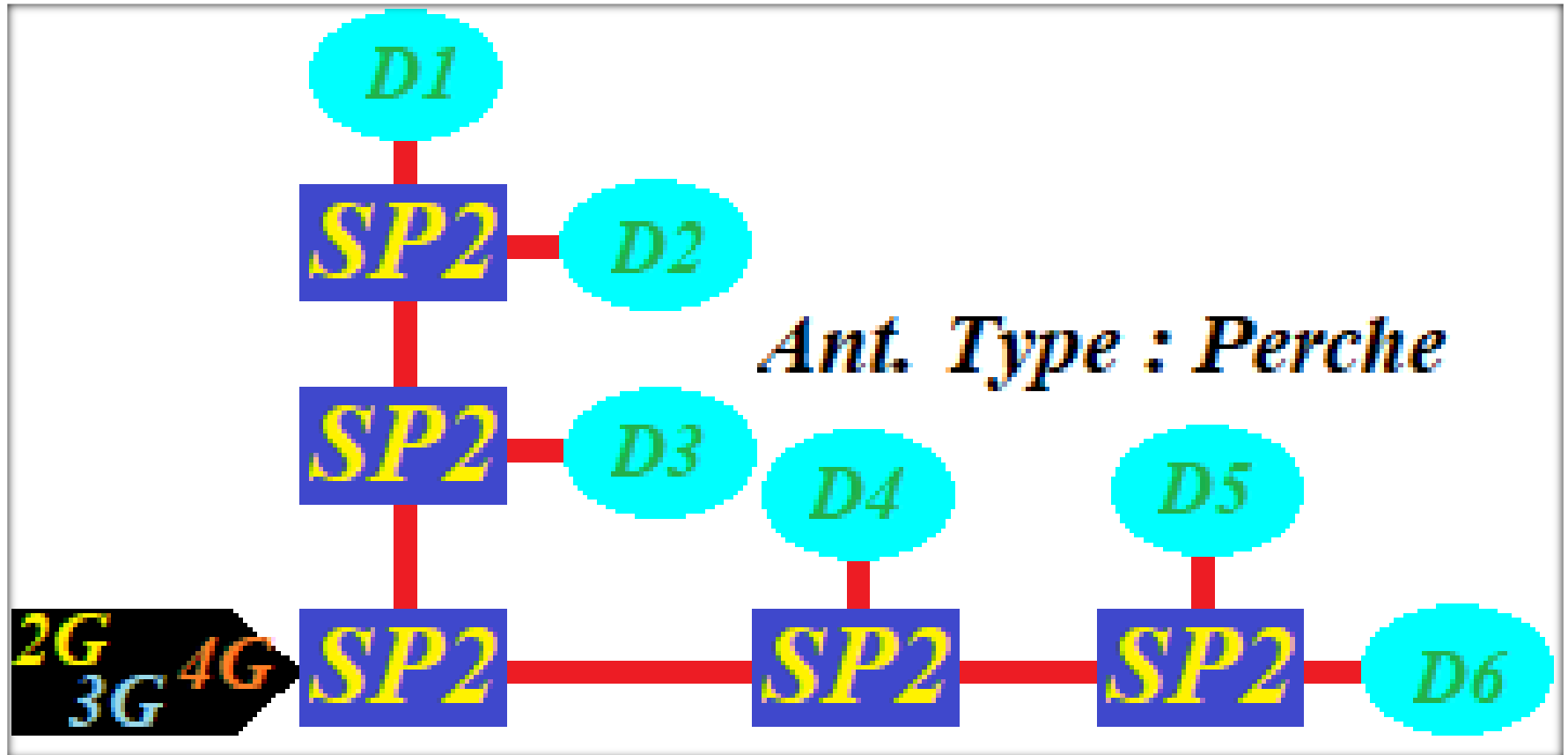



Thank You

